



# MICROFINE

ART NO. 11204

Microfine Round Magnetic Chuck

### Features

- Steel and brass laminated top plate.
- Fully extended poles - minimum loss of working area.
- Detachable handle for easy use.
- Extremely low profile for more wheel area.
- Made with super powerful NdFeB new generation magnets.
- Variable power can be obtained by varying rotation of handle.
- Unique design of the chuck minimizes the deflection of top plate when switched On/Off, resulting in better job accuracy.



### Applications

- Ideal for many tool room applications.
- Enables the grinding of thin objects and small objects that has hitherto been difficult.
- Most suitable for grinding applications, for small to large and thin to thick workpieces.

- Attached to rotary grinders for operation.
- Back plate with tapped hole can be made on request.

All dimensions are in mm.

Art No.	D	Pole Pitch	H
11204.01	100	2 (1.5+0.5)	45
11204.02	130		
11204.03	160		
11204.04	200		
11204.05	250		
11204.06	300		
11204.07	350		
11204.08	400	48	
11204.09	450		
11204.10	500		

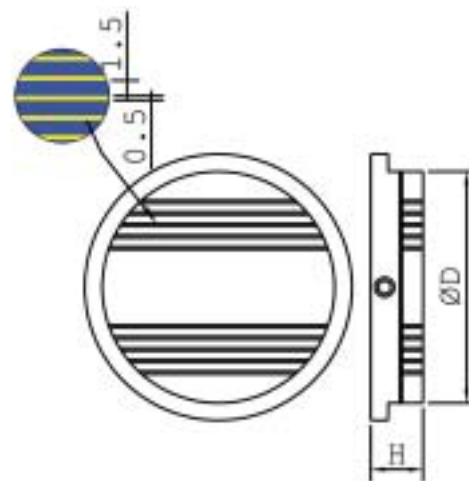

- Due to continuous upgradation in design there could be changes in specifications.
- Other sizes on request.